

Sparkler Battery manual

Technical Specification

Rated Voltage	AC220V/50Hz
peak output power	1600W
Output rating	800W
Fuse	5A (220V)
LCD display	Display power percentage
Mini-K working hours under full power	>120min
MR-K working hours under full power	>120min
Full Charging Time	6-8h
DMX	Support
Lithium battery	24V20AH
Net weight	7.3Kg
Gross weight	8.0kg
machine size	270*250*160mm
Carton size:	305*285*180mm
Cycle life	Over 800 times

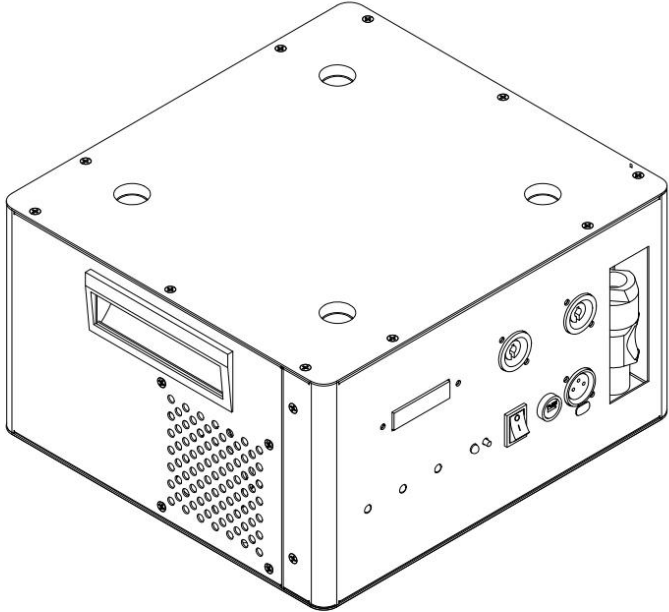

1.Introduction:

Thank you for choosing the product.

We recommend that you carefully read these operating instructions before commissioning the unit. Please follow the instructions in this manual. This is the only way to ensure safe operation, proper use and long service life.

Feature:

◆ The spark machine mobile power solves the problem that it can not normally supply power to the spark machine in outdoor activities. with wireless DMX function, as long as a transmitter can control more than one at the same time, integrating function of power supply and charging of portable power supply, can be more than one series charging at the same time, the convenience of transport, the products are widely used in small and medium-sized outdoor activities, etc.

appearance:

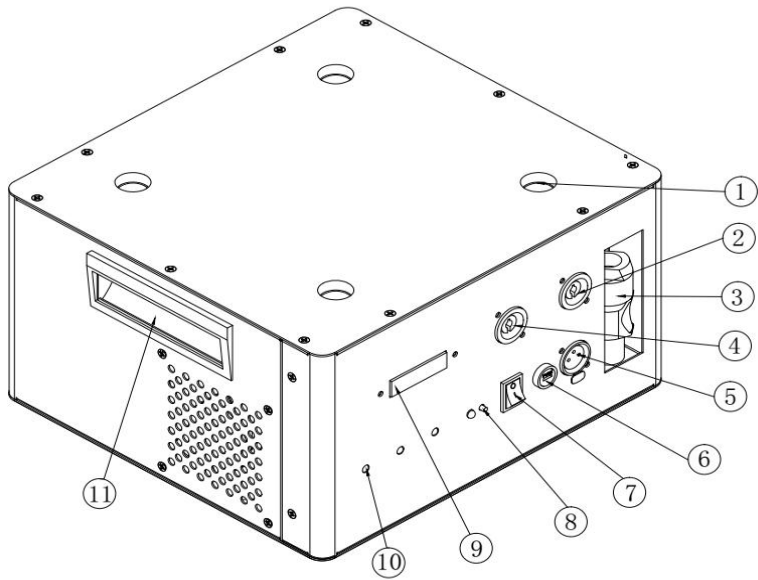

- | | | |
|-----------------------------|-----------------------------|----------------------------------|
| 1、spark machine place | 2、Charging output interface | 3、 Power supply output interface |
| 4、 Charging input interface | 5、 DMX out | 6、 fuse holder |
| 7、 switch | 8、 ID code button | 9、 display screen |
| 10、 Indicator light | 11、 handle | |

WARRANTY CARD

MODEL: _____ (REQUIRED)
 NAME: _____ (REQUIRED)
 DATE OF PURCHASE: _____ (REQUIRED)
 DEALER NAME: _____ (REQUIRED)
 ADDRESS OF DEALER: _____ PROVINCE _____ CITY _____
 _____ DISTRICT _____

NOTES: Fill out the warranty card clearly so that we can solve it for you soon! Please send back the machine with warranty card for repairs.

RECORD CARD FOR MANUFACTURER

1.MAINTENANCE:

SYMPTOM(FOR USER):

_____ (REQUIRED)

MAINTENANCE TIME(FOR MANUFACTURER):

_____ (REQUIRED)

FAULT CAUSE(FOR MANUFACTURER):

_____ (REQUIRED)

2.MAINTENANCE:

SYMPTOM(FOR USER):

_____ (REQUIRED)

MAINTENANCE TIME(FOR MANUFACTURER):

_____ (REQUIRED)

FAULT CAUSE(FOR MANUFACTURER):

_____ (REQUIRED)

3.MAINTENANCE:

SYMPTOM(FOR USER):

_____ (REQUIRED)

MAINTENANCE TIME(FOR MANUFACTURER):

_____ (REQUIRED)

FAULT CAUSE(FOR MANUFACTURER):

_____ (REQUIRED)

◆ When charging, turn the switch to the “CHARGING” position to charge. The red indicator light indicates charging, green indicates full, reset the switch to “OFF” position when charging is finished, and then unplug the power.

4.Maintenance methods:

◆ When the machine does not supply power to the spark machine, if the power is lower than %20, please charge it in time; if it is not used for a long time, perform a full charge at least 2 months.

◆ Do not charge for longer than 12 hours.

◆ Do not place the machine in damp or stagnant water.

6.Warranty Instructions

◆ Warranty period: one year(the date of purchase)

◆ IF the buyers do not use the same supplier ' s powder,the machine warranty period will b e 3 month. The buyer will pay for the expenses if there are any components changes.

◆ In such In the following cases, the product will not be guaranteed:

A: the product has been incorrectly operated and used inadvertently, for example, over load, over pressure, and firing;

B: the product was broken because of careless handling;

C: due to poor use of environmental factors and sound quality problems, such as: humidity, voltage instability, etc.;

D: products have been modified by non factory personnel.

◆ products comply with the warranty provisions, the factory will not charge maintenance fees and accessories costs, for more than the warranty period of the product, only the corresponding parts, finished goods costs.

◆ the contents of this warranty card, the company has the right to interpret, if the user is unknown, please contact the local distributors.

◆ not covered by the warranty include: packing box, packaging, product shell and hanger, remote control transmitter battery.

1.Brief introduction

*Important environmental information about this product.

> This symbol on the device or the package indicates that disposal of the device after its life cycle could harm the environment.

> Do not dispose of the unit (or components) as unsorted municipal waste; it should be taken to a specialized company for recycling.

> This device can be returned to your distributor or to a local recycling center..

> Respect local environmental rules and the environment.

> If in doubt, contact your local waste disposal authorities.

> Thank you for choosing our products. If the device was damaged in transit, don't operate or install the unit and contact your dealer.

2.Safety Instruction

◆ This machine is not waterproof, please pay attention to keep the machine dry. Can not be placed sideways, inverted.。

◆ Please confirm whether the rated voltage is consistent with the rated voltage of the battery. Please turn off the power when not in use.

◆ The machine is for adults only. Please install it where children can't touch it.

◆ Please put the machine in a well ventilated environment. Please reserve 50cm space around the machine.

◆ If there is any abnormal phenomenon, please stop using the machine immediately and turn off the power.

3.General Guidelines

a:The machine must be placed in a well ventilated place. Do not cover anything. It can cause heat to not dissipate and may cause a fire.

b:Before use, please ensure that the rated power of the spark machine is not greater than the rated power of the battery, otherwise the machine will alarm due to overload and will stop working.

c:For those who do not have any maintenance knowledge of the machine, please do not reset the machine and open the machine structure to avoid any danger.

d:This machine is only for adults.Keep it away from children.

e:when the spark machine began to work, because the current is too large, the amount of electricity will have a certain range of decline, this is a normal phenomenon.

f:Do not charge in high temperature or sunlight.Keep the machine away from high temperature heat source or prolonged exposure to the sun;

3.Indicator light status:

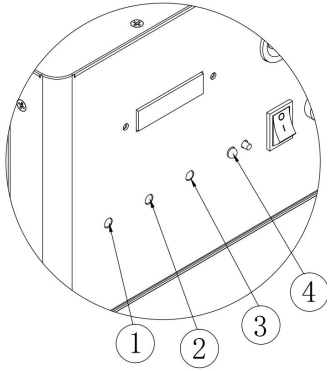

- ◆ Charging light: a red light indicates charging and a green light indicates full.
- ◆ power light: The light indicates that the machine is working normally
- ◆ The machine is shut down due to over pressure/underpressure/overload/over-temperature
- ◆ DMX light: Constant light means no DMX or wireless signal, green LED flashing means receiving, red LED flashing means sending.

4.Installation method

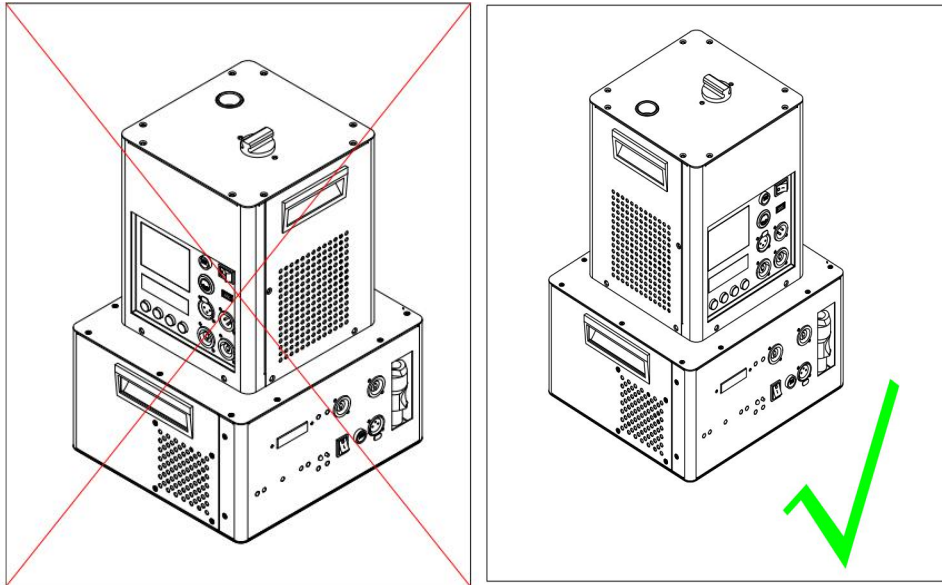

Spark machine on the machine above the hole, the control panel to be consistent with the control surface of the machine, and then pull out the power output connector to spark mechanical and electrical source input end.

5.Menu operation

1.Wireless DMX512 description:

◆ The wireless DMX512 transceiver module transmits standard DMX512 data in a wireless manner, solving the remote wireless transmission between the sparkler and DMX console, completely removing the long-relied twisted pair. In the data transmission process to achieve no delay, real-time data reliable! The module adopts 2.4g global open ISM frequency band, which is free of license. Highly efficient GFSK modulation, 126 channel automatic frequency hopping communication design, strong anti-interference ability.

2.The ID code of wireless DMX corresponds to the LED color:

- ◆ 1: red 2: green 3: yellow 4: blue 5: purple 6: green 7: white
- ◆ Press the button to display the current ID setting, then press to set the ID. Each time you press the ID value, add 1
 - ◆ Working state:
 - a.LED constant light means no DMX or wireless signal.
 - b.Green LED flashes indicate reception.
 - ◆ RF frequency:2.400-2.525G, total of 126 frequency bands, automatic selection does not need to be set.
 - ◆ ID code:"1-7" group ID code, adjusted by "SET ID", only the transceiver boards with the same ID code can communicate with each other.
 - ◆ Establishment of communications:
 - a.The transceiver board is energized and the transmitter is connected to the control desk
 - b.Press "SET ID" to SET the same transceiver board for communication. If you want to use more than one set of wireless networks in the same place, the ID of each network is not the same.
 - c.After receiving the DMX data, the transmitter selects the interference-free frequency band to send the data red flashing, and the receiver changes the communication frequency band until the correct data of the same ID code is received. At this time, the green LED flashes, and the faster the DMX data, the faster the LED blinks.
 - d.The communication was officially established.

3.Wireless DMX512 description:

◆ When the switch is turned to the "ON" position, the machine starts to supply power to the spark machine.