

---

# Mini1000W BSWF LED USER MANUAL



Please read the instructions carefully before use

---

1. Precautions and installation	1
1.1 Statement	1
1.2 Maintenance	1
1.3 Product Precautions	1
1.4 Product Introduction	1
1.5 Connecting Signal Cables	2
1.6 Installation of Lamps	2
2. Control Panel	4
2.1 Key Description	4
2.2 Main Menu	5
2.2.1 DMX Settings	5
2.2.2 Switching between Medium and En	5
2.2.3 Lamp Information	6
2.2.4 Lighting setup	7
2.2.5 Running Mode	8
2.2.6 Factory Settings	9
3. Channel function	10
3.1 Table of channels	10
4. Common faults	13

---

## 1. Precautions for Installation Precautions for installation

### 1.1 The statement

Thank you for choosing our products! This product at the factory, the performance is intact, the package is complete. For your safe and effective use of this product, please read this manual carefully and completely before you use this product. This instruction manual contains important information for installation and use. Please install and operate according to the instructions. Meanwhile, please keep this instruction manual properly for use at any time. Our company does not assume any responsibility for the damage of lamps or other performance due to the failure of individuals to follow the instructions during installation, use or maintenance.

This manual is subject to technical change without prior notice.

### 1.2 Maintenance and maintenance

- Please disconnect the power supply before maintenance.
- The lamp should be kept dry and avoid working in wet environment.
- Intermittent use will effectively extend the life of the lamp.
- For good ventilation and lighting, take care to clean the fan and fan net as well as the lens frequently.
- Do not rub the lamp shell with alcohol and other organic solvents to avoid damage.

### 1.3 Product Precautions

- This lamp is for professional use only.
- Before running, ensure that the power supply voltage is consistent with the required power supply voltage.
- Do not place the product in a place that is easy to loosen or vibrate.
- In the process of use, if the lamp is abnormal, it should stop using the lamp in time.
- In order to ensure the service life of the product, the product should not be placed in a damp or leaking place, and should not work in an environment where the temperature exceeds 60 degrees.
- When the bulb is used, the power supply voltage should not be more than  $\pm 10\%$ . If the voltage is too high, the life of the bulb will be shortened. If the voltage is too low, the light color of the bulb will be affected.
- After power failure, it takes 20 minutes for the lamp to be fully cooled before it can be powered on again.
- The rotating part of the lamp and the sticking parts must be checked regularly. If loose or shaking occurs, it should be reinforced in time to prevent accidents.
- To ensure the normal use of this product, please read the instructions carefully.

### 1.4 Product Introduction

- Input voltage: AC100-240V, 50/60Hz
- Rated power: 1150W
- Light source: 800W LED module
- LED life: 20,000 hours

- Color temperature: 7000K
- Caliber: 130mm Frontal lens for greater performance
- Color rendering index: Standard mode Ra>70, high CRI mode Ra>90
- Luminous flux:24000LM
- Signal interface: three-pin XLR (five-pin XLR optional)
- Control mode: DMX512, RDM, Auto Mode, master-slave, Sound activation
- Channel mode: 36CH、42CH、60CH、41CH Same channel as Martin profile(choosable)
- Display system: 2.8-inch touch LCD display, Chinese and English display, 180-degree rotation
- Fixed color: 6 colors + open position
- Color mixing system: independent CMY color mixing system
- Color temperature adjustment: independent CTO 2500K-7000K linear adjustment
- Prisms: Rotating 4-faced prism+6-faced linear prism, two prisms can be overlaid
- Effect wheel: dynamic effects such as stunning simulated dynamic flames, gurgling water, etc.
- Fixed Gobo wheel: 7 plug-in fixed gobos with an outer
- Rotating gobo Wheel: 8 gobos (pluggable), (Inner 16mm, outer 25.4mm, thick 1.0mm)
- Framing system: 4 Individually positionable Shutter Blades, each piece can be closed separately and can be rotated +/- 120°
- Frost system: 0~100% linear atomization
- Iris system: 6%~100% smooth adjustment
- Beam Aperture: 5°~50° fast motorized linear zoom
- Dimming system: 0-100% linear adjustment
- Strobe system: the highest frequency can reach 25Hz, and random strobe and pulse strobe can be selected
- Pan: 540° (16 bit precision scanning)
- Tilt: 270° (16 bit precision scanning)
- Pan/Tilt: Five-phase motor with magnetic encoding positioning function
- Protection rate: IP20
- Working environment: 0-45°C
- Product size: 703\*416\*501mm
- Carton size: 750\*360\*505mm
- Product net weight: 32KG
- Product gross weight: 36KG

## Rotating Gobo wheel

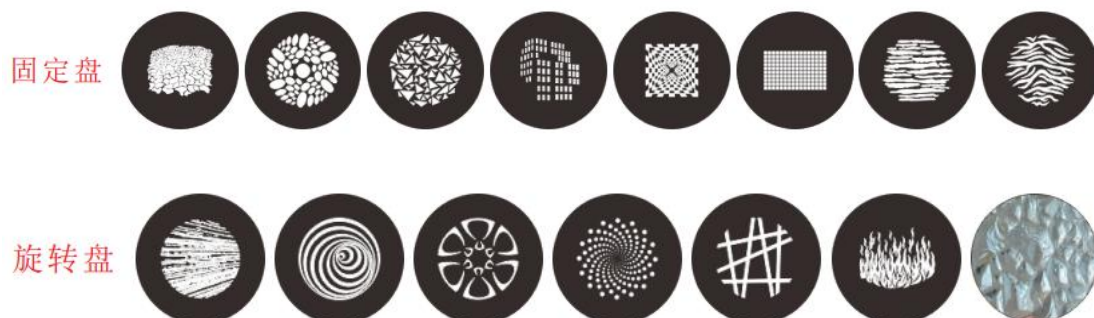

## Color wheel

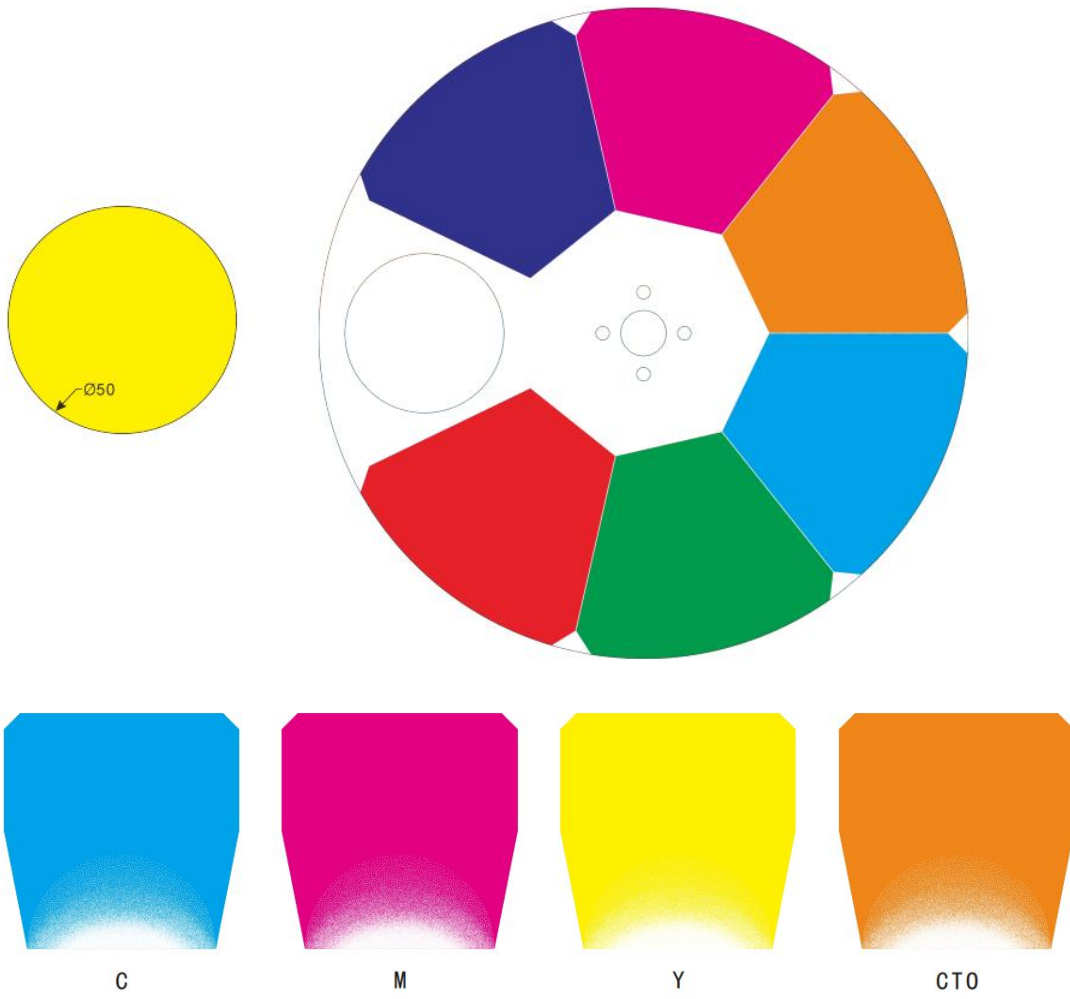

## Effect Flame Wheel

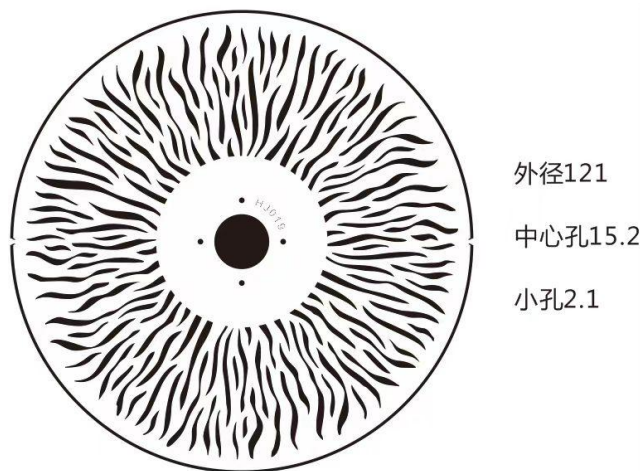

## Signal wire connection

Lamps feature standard DMX input and output 3-core or 5-core XLR sockets. Please use DMX 512 shielded twisted-pair signal cable; The signal line is generally connected at a distance of 150 meters, and the DMX512 signal amplifier must be added when the long-distance signal is transmitted.

Connect a shielded twisted-pair signal line from the DMX outlet of the controller to the DMX input of the first device, and from the DMX input of the first device to the DMX input of the second device, and so on, until all lights are connected. Then install a terminal plug on the last connecting 3-core jack of the light fixture output in each row.(Weld a 4/1W, 120Ω resistance between pins 2 and 3 of the 3-core pin cannon plug).

**Important:** Wires should not touch each other or the metal case.

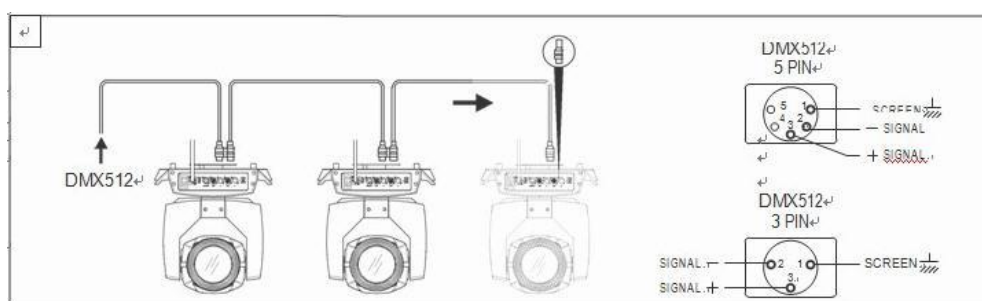

Figure 1 Schematic diagram of DMX signal cable connection

### ➤ Calculation method of initial address code of lamps:

The initial address code of the current lamp is equal to (the initial address code of the previous lamp)+(the number of channels of the lamp)

1: The starting address code of the first lamp is A001.

2: The basic channel number of the controller should be greater than or equal to the total number of channels used by the lamp.

3: Note: when using any controller, each lamp should have its own initial address code, if the first lamp's initial address code is set A001, the lamp channel number is 16CH;Then the initial address code of the second lamp is set to A017;The starting address code of the third lamp is set to A033;And so on. (This setting mode also needs to be determined according to different console)

## 1.5 Installation of lamps

Lamps can be placed horizontally, slanted or hung upside down. Pay attention to the installation method when hanging it slanting or upside down.

As shown in Figure 2, before positioning the lamp, the stability of the installation site should be ensured. During the reverse hanging installation, the lamp must not fall down on the support frame, and the safety rope should be used to pass through the support frame and the lamp handle for auxiliary hanging to ensure safety. Prevent lamps from falling and sliding.

When the lamp is installed and adjusted, pedestrians are not allowed to pass under it. Periodically check whether the safety rope is worn and whether the hook screw is loose.

Our company does not assume any responsibility for all the consequences caused by the fall of the lamp due to the unstable installation of the hanging.

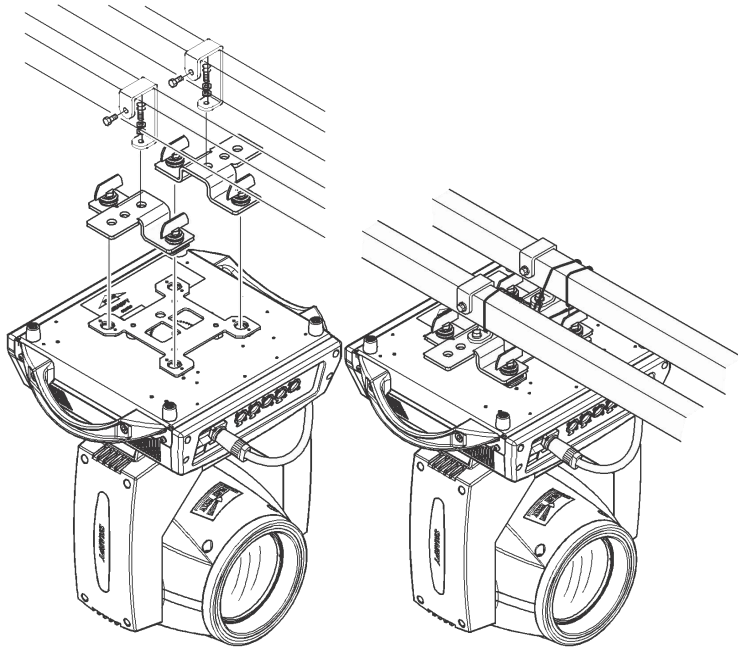
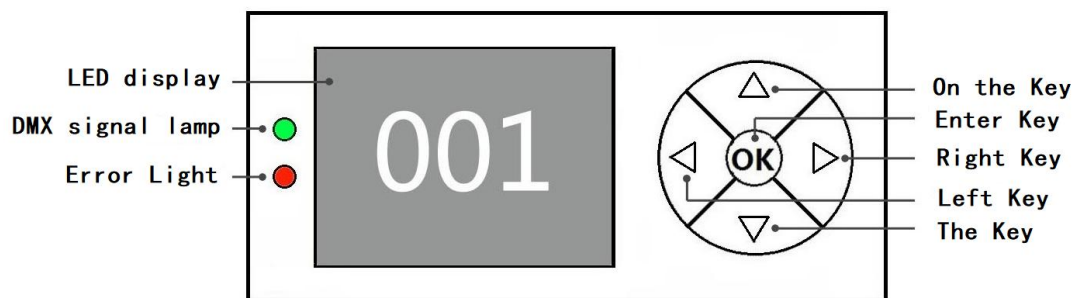

Figure 2. Schematic diagram of hanging lamps upside down

## 2. Control panel

### 2.1 Key Description



The function of the left and right keys is the same: return to the previous interface

Up, down keys: Select, edit

OK Key: Perform function, start edit, exit edit

Figure 3. Description of panel keys

The following takes "Modify DMX address code" as an example to describe the use of keys:

1. If the current home screen is not displayed, press the Left key (one or more times) to return to the home screen
2. On the home screen, press the Up or Down key to select the Settings button
3. Press the OK key to enter the Settings screen
4. In the "Settings" interface, press the "Up" key or "Down" key to select "DMX Address"
5. Press "OK" to enter the editing state
6. Press the "Up" key or "Down" key to modify the DMX address code
7. Press the "OK" key to exit the editing state
8. Press the right button on the main interface to enter the calibration menu.

## 2.2 Menu Description



Figure 4 Main menu diagram

### 2.2.1 DMX Settings

Key description: Press up or down to +1 or -1 mode; Press one or the next, quickly adjust the address code mode; Press the Confirm key to return

Manual instruction: Enter the hundreds place, then the tens place, and then the last place.(For example, if you enter 286, click 2, then 8, and finally 6)

### 2.2.2 Medium /En

English and Chinese interface switch;

### 2.2.3 System Information

options	instructions	
System version	DIS	Display board software version
	MT	Motor board software version
Temperature information		Display bead temperature
Fan Information	Fan speed	Displays fan speed information
System time	Total bright bubble	Cumulative brightening time (accurate to minutes)
	This brightening bubble	The brightening time (accurate to minute)
	Total service time	Cumulative usage time (accurate to minutes)
	Time of use	Usage time since this startup (accurate to minutes)
	Date of manufacture	
	Permission Duration	9999 indicates no encryption and can be used for a long time. Other values represent the remaining use time, encrypted;
Sensor monitoring	X Hall	0 when magnetic is detected, 1 otherwise
	Y Hall	0 when magnetic is detected, 1 otherwise
	Color plate hall	0 when magnetic is detected, 1 otherwise
	CMY Hall	0 when magnetic is detected, 1 otherwise
	CTO Hall	0 when magnetic is detected, 1 otherwise
	Fixed pattern pan	0 when magnetic is detected, 1 otherwise
	Glass pattern hall	0 when magnetic is detected, 1 otherwise
	Glass pattern rotation Hall	0 when magnetic is detected, 1 otherwise
	Focus hall	0 when magnetic is detected, 1 otherwise
	Enlarge Hall	0 when magnetic is detected, 1 otherwise
	Prism 1 rotary hall	0 when magnetic is detected, 1 otherwise
	X Code disk status	Two digits, each corresponding to a photoelectric switch in the code disc
	Y Code disk status	Two digits, each corresponding to a photoelectric switch in the code disc
	X-axis encoding	The number of steps should increase when

	disk step value	walking in the forward direction and decrease when walking in the opposite direction. Every time you go to the same point, the value is normal
	Y-axis encoding disk step value	The number of steps should increase when walking in the forward direction and decrease when walking in the opposite direction. Every time you go to the same point, the value is normal
System error		If the red ERR indicator lights up, it indicates that the lamp is running incorrectly. You can enter the sub-interface to check the details. After viewing, you can press the "Clear" key to clear the error record
DMX channel value monitoring		The sub-screen displays the channel value in numerical and percentage terms for viewing

Common Error Messages	instructions	
Failed to connect the MT board. Procedure	The motor board is not responding. The serial communication line connecting the display board and the motor board is faulty, or the motor board is faulty.	
X-axis reset failed	X-axis photoelectric switch, or X-axis motor or motor board has a problem	
Y-axis reset failed	Y-axis photoelectric switch, or Y-axis motor or motor board is faulty	
X axis Hall error	There is a problem with X shaft Hall or motor board	
Y-axis Hall error	Y-shaft Hall, or motor board problem	
Description Failed to reset the color disk	Color plate hall, or color plate motor has a problem	
Description The pattern disk failed to reset	Pattern plate hall, or pattern plate motor problem	
Failed to reset the focus	The focusing hall, or the focusing motor has a problem	

#### 2.2.4 Lighting setup

options	instructions	
DMX channel	36CH	36 channel mode
Work Mode	Standard	Standard mode suitable for outdoors

	Theater	Suitable for indoor high environment
	Television	Suitable for indoor small space environment
language	Chinese	Set the interface to Chinese
	English	Set the interface to English
Screen flip	OFF	Front face display
	ON	The screen is displayed in reverse
Automatic screen flip	OFF	Disable the automatic flip function
	ON	Gravity sensing automatically reverses
Dimming curve	Square	index
	linear	A straight line
	SCurve	sine
	InSquare	logarithmic
RDM Function	OFF	The RDM function is enabled
	ON	Disable the RDM function
DMX signal	Hold	Continue running in the original state
	Reset	The motor turns back and stops running
Screen saver	OFF	Turn off the screensaver
	ON	Open the screensaver
Light tracing mode	OFF	Shut down
	Mode 1	XY has no power in light pursuit mode
	Mode 2	Very low intensity in XY mode
X reversal	OFF	The default
	ON	The starting point and the ending point are switched
Reversal of Y	OFF	The default
	ON	The starting point and the ending point are switched
XY exchange	OFF	The default
	ON	Exchange XY axis channel (including fine )
XY encoder	ON	Use an encoder (optocoupler) to determine the out-of-step and automatically correct the position
	OFF	No encoder (optocoupler) is used to correct the position
Restore Default Settings		After you press the OK key, the confirmation dialog box is displayed. Press the OK key again to restore the default Settings

### 2.2.5 Running Mode

Self walking mode	DMX	Slave state: Receives DMX signals from the console or host
	Since the go	Host state: Self-drive and send DMX signal to slave
	Scenario 1, 2, 3	Turn on scene self - walk
	Program 1, 2, 3	Call console programming program to walk
Scenario Running	all	All open scenarios run sequentially
	From 1 to 5	Call a scene run individually
Scene Setting	Scene channel	Edit number Press the "Confirm" button to save

	Saving	(display: saving)
	Multi-step scenario group	1, 2, 3; There are three groups
	Scene step selection	Under the current group, switch to the number of steps you want to edit
	Scene time (s)	1-100. Total time for each step to run
	Scene delay (%)	0-100; Gradient percentage, 0 is direct jump;
	Scenario Running	Open, running mode all can be called; Closing can only be invoked separately
	1 to 36 Channel values	
Console programming	Program 1, 2, 3	Switch the program position to record, press the "Confirm" button to enter the programming record interface, need to connect to the console
	Time (S)	Set the running time for each step
	They count	Current step of program
	Clearing Data	Clear all data of the current program
Console programming >> Programming interface		Adjust the number of steps up and down, connect the console to save;

Manual control (Click the operation mode menu on the main interface, select the item manual control, and press "Confirm" to enter manual control)

This interface is used to control the current lamp and automatically enter the host state (no DMX signal is received, in self-walking mode is the host, and sends DMX signal to the bus to the slave machine).

The manual menu displays 36 channels according to the standard 36 channels set in the Settings menu.

options	instructions	
1CH. X	0 ~ 255	Press the "OK" key to enter the editing state.
...	0 ~ 255	Select the hundreds digit and press the Up and
35CH. Iris	0 ~ 255	Down keys to change the channel value. Press OK again to select the tens edit. Press "OK" again to select the ones bit edit. Press again to exit the editing state
36CH. Reset		Press the "OK" button and see the confirmation dialog box. Press the "OK" button again to enter the reset interface and reset all the motors

Reset ALL		Press the "OK" button and see the confirmation dialog box. Press the "OK" button again to enter the reset interface and reset all the motors
XY reset		Press the "OK" button to see the confirmation dialog box. Press the "OK" button again to enter the reset interface and reset XY

MT reset		Press the "OK" button and see the confirmation dialog box. Press the "OK" button again to enter the reset interface and reset the small motor
----------	--	--

## 2.2.6 Factory Settings

options	instructions	
Calibration of motor	PAN	After entering the sub-interface, you can adjust the reset position of X axis, Y axis and other motors to make up for the error in hardware installation. The adjustment range is -128 to +127, and +0 indicates no adjustment.
	TILT	
	Color Wheel	
	Fixed Gobo wheel	
	Glass Gobo wheel	
	Glass Gobo wheel rotation	
	Animation Wheel zero point	
	Animation Wheel Stroke	
	CRI Zero	
	CRI Stroke	
	Color temperature	
	Cyan	
	Magenta	
	Yellow	
	Focusing	
	Zoom	
	Prism 1 zero point	
	Prism 1 stroke	
	Prism 2 zero point	
	Prism 2 stroke	
	Prism 1 rotation	
	Prism 2 rotation	
	Zero point of atomization	
	Stroke of atomization	
	Framing Plate Rotation	
	Iris	
	Framing Plate 1	
	Framing Plate 2	
Framing Plate 3		
Framing Plate 4		

	Framing Plate 5	
	Framing Plate 6	
	Framing Plate 7	
	Framing Plate 8	
Pan/Tilt speed adjustment	Pan Speed	000-255, speed slow to fast adjustment
	Tilt Speed	
Regulation of fan	Regulation of fan	Only do temporary adjustment, power does not save
	Fan speed	

### 3. Function of channel

#### 4. 3.1 Table of channels

Channel mode					
Channel 36		Channel 42		Channel 60	
1	Pan	1	Pan	1	Pan
2	Pan fine	2	Pan fine	2	Pan fine
3	Tilt	3	Tilt	3	Tilt
4	Tilt fine	4	Tilt fine	4	Tilt fine
5	Pan/Tilt Speed	5	Pan/Tilt Speed	5	Pan/Tilt Speed
6	Shutter/Strobe	6	Shutter/Strobe	6	Shutter/Strobe
7	The dimmer	7	The dimmer	7	The dimmer
8	C	8	Dimming fine	8	Dimming fine
9	M	9	Zoom	9	Zoom
10	Y	10	Zoom Fine	10	Zoom Fine
11	CTO	11	Focus	11	Focus
12	Color Wheel	12	Focus Fine	12	Focus Fine
13	CRI Filter	13	Auto Focus	13	Auto Focus
14	Fixed Gobo Wheel	14	Auto Focus Fine	14	Auto Focus Fine
15	Rotating Gobo Wheel	15	Color Wheel	15	Color Wheel
16	Rotating Glass Gobo Wheel Rotation	16	CRI Filter	16	Color Wheel Fine
17	Animation Wheel	17	C	17	CRI Filter
18	Animation wheel Rotation	18	M	18	CRI Filter Fine
19	Focus	19	Y	19	C
20	Focus Fine	20	CTO	20	C Fine
21	Zoom	21	Fixed Gobo Wheel	21	M

22	Prism 1+2	22	Rotating Gobo Wheel	22	M Fine
23	Prism 1 Rotation	23	Rotating Gobo Wheel Rotation	23	Y
24	Prism 2 Rotation	24	Rotating Gobo Wheel Rotation Fine	24	Y Fine
25	Frost	25	Animation insertion	25	CTO
26	Framing Blade 1	26	Animation Wheel	26	CTO fine
27	Framing Blade 2	27	Iris	27	Fixed Gobo Wheel
28	Framing Blade 3	28	Prism 1	28	Glass Gobo Wheel
29	Framing Blade 4	29	Rotation of prism 1	29	Glass Gobo Wheel Rotation
30	Framing Blade 5	30	Prism 2	30	Glass Gobo Wheel Rotation Fine
31	Framing Blade 6	31	Rotation of prism 2	31	Animation Wheel insertion
32	Framing Blade 7	32	Frost	32	Animation Wheel
33	Framing Blade 8	33	Framing Blade 1	33	Iris
34	Framing wheel	34	Framing Blade 2	34	Iris Fine
35	Iris	35	Framing Blade 3	35	Prism 1
36	Function	36	Framing Blade 4	36	Prism 1 self-rotating
		37	Framing Blade 5	37	Prism 1 rotation fine
		38	Framing Blade 6	38	Prism 2
		39	Framing Blade 7	39	Prism 2 self-rotating
		40	Framing Blade 8	40	Prism 2 rotation fine
		41	Framing Wheel	41	Frost
		42	Function	42	Framing Blade 1
				43	Framing Blade 1 Fine
				44	Framing Blade 2
				45	Framing Blade 2 Fine

				46	Framing Blade 3
				47	Framing Blade 3 Fine
				48	Framing Blade 4
				49	Framing Blade 4 Fine
				50	Framing Blade 5
				51	Framing Blade 5 Fine
				52	Framing Blade 6
				53	Framing Blade 6 Fine
				54	Framing Blade 7
				55	Framing Blade 7 Fine
				56	Framing Blade 8
				57	Framing Blade 8 Fine
				58	Framing Wheel
				59	Framing Wheel fine
				60	Function

## Channel parameter values (full version) :

### Parameter values (full version) :

Channel 36	The name of the	The numerical	describe
CH1	Pan	0-255	0-540degree
CH2	Pan Fine	0-255.	0-2 degrees
CH3	Tilt	0-255.	0-270 degrees
CH4	Tilt Fine	0-255.	0-1 degrees
CH5	Pan/Tilt Speed	0-255.	From fast to slow
CH6	Strobe	0-3	No function
		4-127.	From slow to fast normal strobe
		128-191.	Bisect strobe from slow to fast
		192-251.	From slow to fast random strobe
		252-255.	Light On

CH7	The dimmer	0-255.	0-100% dimming
CH8	C	0-255.	
CH9	M	0-255.	
CH10	Y	0-255.	
CH11	CTO	0-255.	
CH12	Color Wheel	0-127.	Linear color
		128-137	Color 1
		138-146	Color 2
		147-155	Color 3
		156-164	Color 4
		165-173	Color 5
		174-182	Color 6
		183-191	Color 7
		192-222.	CW From fast to slow
		223-224.	Stop
CH13	CRI Filter	0	No function
		1-255.	0-100% linear insertion
CH14	Fixed Gobo	0-9	Open
		10-19	Gobo 1
		20-29	Gobo 2
		30-39	Gobo 3
		40-49	Gobo 4
		50-59	Gobo 5
		60-69	Gobo 6
		70-79	Gobo 7
		80-89	Gobo 8
		90-99	From slow to fast Gobo 1 Shake
		100-109	From slow to fast Gobo 2 Shake
		110-119	From slow to fast Gobo 3 Shake
		120-129	From slow to fast Gobo 4 Shake
		130-139	From slow to fast Gobo 5 Shake
		140-149	From slow to fast Gobo 6 Shake
		150-159	From slow to fast Gobo 7 Shake
		160-169	From slow to fast Gobo 8 Shake
170-212	CW From fast to slow		
213-215	Stop		
216-255	CCW From slow to fast		
CH15	Glass Wheel Gobo	0-9	Open
		10-19	Gobo 1

		20-29	Gobo 2
		30-39	Gobo 3
		40-49	Gobo 4
		50-59	Gobo 5
		60-69	Gobo 6
		70-79	Gobo 7
		80-89.	From slow to fast Gobo 1 Shake
		90-99.	From slow to fast Gobo 2 Shake
		100-109.	From slow to fast Gobo 3 Shake
		110-119.	From slow to fast Gobo 4 Shake
		120-129.	From slow to fast Gobo 5 Shake
		130-139.	From slow to fast Gobo 6 Shake
		140-149.	From slow to fast Gobo 7 Shake
		150-190.	CW From fast to slow
		191-192.	Stop
		193-255.	CCW From slow to fast
CH16	Glass Gobo wheel rotation	0-127.	Angle Switch
		128-190.	CW From fast to slow
		191-192.	Stop
		193-255.	CCW From slow to fast
CH17	Animation Wheel Insertion	0-9	OFF
		10-255.	Linear insertion
CH18	Animation Wheel	0-2	Stop
		3-128.	CW From fast to slow
		129-255.	CCW From slow to fast
CH19	Focus	0-255.	From far to near
CH20	Focus Fine	0-255.	
CH21	Zoom	0-255.	From small to big
CH22	Prism 1	0-63.	OFF
		64-127.	Prism 1
		128-191.	Prism 2
		192-255.	Prism 1+ Prism 2
CH23	Prism 1 Rotation	0-127.	Angle Switch
		128-187.	CW From fast to slow
		188-195.	Stop
		196-255.	CCW From slow to fast
CH24	Rotation of prism 2	0-127.	Angle Switch
		128-187.	CW From fast to slow
		188-195.	Stop
		196-255.	CCW From slow to fast
CH25	Frost	0-127.	No function
		128-255.	Frost

CH26	Framing Blade 1	0-255.	Linear insertion
CH27	Framing Blade 2	0-255.	Linear insertion
CH28	Framing Blade 3	0-255.	Linear insertion
CH29	Framing Blade 4	0-255.	Linear insertion
CH30	Framing Blade 5	0-255.	Linear insertion
CH31	Framing Blade 6	0-255.	Linear insertion
CH32	Framing Blade 7	0-255.	Linear insertion
CH33	Framing Blade 8	0-255.	Linear insertion
CH34	Framing Wheel	0-255.	Angle of slice
CH35	Iris	0-127. 128-255.	From big to small Function of contraction
CH36	Function	0-100.	Follow Spot Default (follow Settings)
		101-110.	Turn off follow spot mode and hold it for 5s without changing the interface Settings
		111-120.	Follow spot mode 1: Hold for 5s without changing the interface Settings
		121-130.	FollowSpot 2: Hold for 5s without changing the interface Settings
		210-215.	Reset Pan/Tilt for More than 6 seconds
		220-235.	Reset Effect Motor for More than 6 seconds
		240-255.	Reset all after 6 seconds

Channel 42	Channel 60	The name of the	The numerical	Description
CH1	CH1	Pan	0-255.	0-540 degrees
CH2	CH2	Pan Fine	0-255.	0-2 degrees
CH3	CH3	Tilt	0-255.	0-270 degrees
CH4	CH4	Tilt Fine	0-255.	0-1 degrees
CH5	CH5	Pan/Tilt	0-255.	From fast to slow
CH6	CH6	Strobe	0-3	No function
			4-127.	From slow to fast normal strobe
			128-191.	Bisect strobe from slow to fast
			192-251.	From slow to fast random strobe
			252-255.	Light On
CH7	CH7	Dimmer	0-255.	0-100% dimming
CH8	CH8	Dimming fine	0-255.	
CH9	CH9	Zoom	0-255.	From small to big
CH10	CH10	Zoom Fine		
CH11	CH11	Focus	0-255.	From far to near

CH12	CH12	Focus fine	0-255.	
CH13	CH13	Auto focus	0-63.	There is no
			64-127.	7.5 meters
			128-255.	15 meters
CH14	CH14	Auto focus fine	0-255.	
CH15	CH15	Color Wheel	0-127	Linear color
			128-137	Color 1
			138-146	Color 2
			147-155	Color 3
			156-164	Color 4
			165-173	Color 5
			174-182	Color 6
			183-191	Color 7
			192-222.	CW From fast to slow
			223-224.	Stop
		225-255.	CCW From slow to fast	
	CH16	Color Wheel Fine		
CH16	CH17	CRI Filter	0	No function
			1-255.	0-100% linear insertion
	CH18	CRI Filter Fine		
CH17	CH19	C	0-255.	
	CH20	C Fine		
CH18	CH21	M	0-255.	
	CH22	M fine		
CH19	CH23	Y	0-255.	
	CH24	Y fine		
CH20	CH25	CTO	0-255.	
	CH26	CTO Fine		
CH21	CH27	Fixed Gobo Wheel	0-9	Open
			10-19	Gobo 1
			20-29	Gobo 2
			30-39	Gobo 3
			40-49	Gobo 4
			50-59	Gobo 5
			60-69	Gobo 6
			70-79	Gobo 7
			80-89	Gobo 8
			90-99	From slow to fast Gobo 1 Shake
			100-109.	From slow to fast Gobo 2 Shake
			110-119.	From slow to fast Gobo 3 Shake

			120-129.	From slow to fast Gobo 4 Shake
			130-139.	From slow to fast Gobo 5 Shake
			140-149.	From slow to fast Gobo 6 Shake
			150-159.	From slow to fast Gobo 7 Shake
			160-169.	From slow to fast Gobo 7 Shake
			170-212.	CW From fast to slow
			213-215.	Stop
			216-255.	CCW From slow to fast
CH22	CH28	Glass Wheel Gobo	0-9	Open
			10-19	Gobo 1
			20-29	Gobo 2
			30-39	Gobo 3
			40-49	Gobo 4
			50-59	Gobo 5
			60-69	Gobo 6
			70-79	Gobo 7
			80-89.	From slow to fast Gobo 1 Shake
			90-99.	From slow to fast Gobo 2 Shake
			100-109.	From slow to fast Gobo 3 Shake
			110-119.	From slow to fast Gobo 4 Shake
			120-129.	From slow to fast Gobo 5 Shake
			130-139.	From slow to fast Gobo 6 Shake
			140-149.	From slow to fast Gobo 7 Shake
			150-190.	CW From fast to slow
			191-192.	Stop
			193-255.	CCW From slow to fast
CH23	CH29	Glass Gobo wheel rotation	0-127.	Angle Switch
			128-190.	CW From fast to slow
			191-192.	Stop
			193-255.	CCW From slow to fast
CH24	CH30	Glass Gobo Rotation fine		
CH25	CH31	Animation	0-9	OFF

		Wheel Insertion	10-255.	Linear insertion
CH26	CH32	Animation Wheel	0-2	Stop
			3-128.	CW From fast to slow
			129-255.	CCW From slow to fast
CH27	CH33	Iris	0-127. 128-255.	From big to small Function of contraction
	CH34	Iris Fine		
CH28	CH35	Prism 1	0-127.	OFF
			128-255.	Prism 1
CH29	CH36	Prism Rotation 1	0-127.	Angle Switch
			128-187.	CW From fast to slow
			188-195.	Stop
			196-255.	CCW From slow to fast
	CH37	Prism 1 rotation fine		
CH30	CH38	Prism 2	0-127.	OFF
			128-255.	Prism 1
CH31	CH39	Prism Rotation 2	0-127.	Angle Switch
			128-187.	CW From fast to slow
			188-195.	Stop
			196-255.	CCW From slow to fast
	CH40	Prism 2 rotation Fine		
CH32	CH41	Frost	0-127.	No function
			128-255.	Frost
CH33	CH42	Framing Blade 1	0-255.	Linear insertion
	CH43	Framing Blade 1 Fine		
CH34	CH44	Framing Blade 2	0-255.	Linear insertion
	CH45	Framing Blade 2 Fine		
CH35	CH46	Framing Blade 3	0-255.	Linear insertion
	CH47	Framing Blade 3 Fine		
CH36	CH48	Framing Blade 4	0-255.	Linear insertion
	CH49	Framing Blade 4 Fine		
CH37	CH50	Framing Blade 5	0-255.	Linear insertion

	CH51	Framing Blade 5 Fine		
CH38	CH52	Framing Blade 6	0-255.	Linear insertion
	CH53	Framing Blade 6 Fine		
CH39	CH54	Framing Blade 7	0-255.	Linear insertion
	CH55	Framing Blade 7 Fine		
CH40	CH56	Framing Blade 8	0-255.	Linear insertion
	CH57	Framing Blade 8 Fine		
CH41	CH58	Framing Wheel	0-255.	Framing Angle
	CH59	Framing Wheel Fine		
CH42	CH60	function	0-100.	Follow Spot Default (follow Settings)
			101-110.	Turn off follow spot mode and hold it for 5s without changing the interface Settings
			111-120.	Follow spot mode 1: Hold for 5s without changing the interface Settings
			121-130.	Follow Spot 2: Hold for 5s without changing the interface Settings
			210-215.	Reset Pan/Tilt for More than 6 seconds
			220-235.	Reset Effect Motor for More than 6 seconds
			240-255.	Reset all after 6 seconds

## 5. Common Faults

According to some common faults, the corresponding solutions are put forward. Any problems that cannot be solved should be dealt with by professionals. Disconnect the light fixture from the power supply before maintaining it.

1. Abnormal problems, causes and solutions of lamps

Problem	Cause	Solution
Motor Reset Failure:	Possible causes are:	
X-axis Reset Error	Obstacle	Check and remove any obstacles that restrict normal operation
Y-axis Reset Error	Hall element damage	Check if the Hall element is damaged
X-axis Hall Error	Magnet detachment	Check if the position where the magnetic steel is installed is detached or damaged
Y-axis Hall Error	Motor damage, poor contact, component damage	Check if the motor is damaged. Check if the relevant circuit on the motor driver board is damaged. Check if the lead wire connecting the motor is in poor contact or disconnected.
Color Reset Failure		
Fixed Pattern Disk Reset Failure		
CMY - Cyan Reset Failure		
CMY - Magenta Reset Failure		
CMY - Yellow Reset Failure		
CTO Reset Failure		
Glass Pattern Reset Failure		
Glass Pattern Rotation Reset Failure		
Mirror Array Rotation Reset Failure		
Focus Reset Failure		
Zoom Reset Failure		
Cutting Reset Failure		
X-axis Step Loss	Error correction occurred on the X-axis, possibly due to excessive speed and insufficient force	Slow down the speed

Y-axis Step Loss	Error correction occurred on the Y-axis, possibly due to excessive speed and insufficient force	Slow down the speed
Prism 1 Rotation Step Loss	Motor misalignment	Slow down the speed
Color Step Loss	Motor misalignment	Slow down the speed
Glass Pattern Rotation Step Loss	Motor misalignment	Slow down the speed
Reset Timeout	Reset took more than 2 minutes, indicating abnormal motor reset	Check if any motor fails to operate
Reset Interrupted	During the reset process, the confirmation key was pressed for more than 5 seconds	It may be that the key is stuck down, or there is something pressing on the touch screen! The key is broken or the screen is broken!
XY Board Connection Failure	Unable to connect to the XY board	The XY board is broken, the communication cable is loose or incorrectly connected
Focus Board Connection Failure	Unable to connect to the focus board	The focus board is broken, the communication cable is loose or incorrectly connected
Color Board Connection Failure	Unable to connect to the color board	The color board is broken, the communication cable is loose or incorrectly connected
Cutting Board Connection Failure	Unable to connect to the cutting board	The cutting board is broken, the communication cable is loose or incorrectly connected
LED Board Connection Failure	Unable to connect to the LED board	The LED board is broken, the communication cable is loose or incorrectly connected
CMY Board Connection Failure	Unable to connect to the CMY board	The CMY board is broken, the communication cable is loose or incorrectly connected

Color Board Error	Unable to connect to the color board	The color board is broken, the communication cable is loose or incorrectly connected
Temperature Error	The temperature control resistor is not connected, or there is a short - circuit (over 90 degrees)	Check if the wiring is correct or if there is a short - circuit

2. The bulb doesn't work.

- Check that the voltage that matches the light fixture is installed;
- Check whether the lamp power supply connection or control switch is in poor contact;
- Check whether the power supply is insufficient;
- Check that the DMX512 controller is sending instructions.

3. The light fixture does not accept control from the console after normal reset

- Check luminaire digital start address value and function options are correct;
- Check whether the connection of the communication control line is correct, the communication line is too long or has been interrupted;
- Check whether the control equipment is invalid, check whether the signal amplifier connected to the series is invalid;
- Check whether the communication line is too long or other devices interfere with each other;
- Optimize wiring, shorten the length of the control signal line, high-voltage and low-voltage lines separate wiring;
- Add signal amplifiers;
- Signal line using high quality shielded twisted pair wire;
- Connect the signal terminal resistor (120 ohms) at the end of the lamp.

4. Luminaire does not start

- Check that the power supply parameters are consistent with the luminaire;
- Check the lamps in the long-distance transportation process due to extrusion deformation, internal parts vibration, moisture and other reasons, resulting in poor contact

---

Or fall off.

- Please check whether the internal wire integration connector of the lamp has fallen off and is loose.
- Check whether the electronic components of the lamp (such as electronic transformer, PCB board, motor control board, etc.) are loose, short circuit and burned out.

5. When working, the action of the X axis or Y axis of the luminaire is abnormal

- Check them one by one by following the previous step;
- Check whether the transmission belt corresponding to the X and Y axis direction in the lamp falls off and breaks;
- Check whether the data feedback receiver (optocoupler) corresponding to the X and Y directions in the lamp is damaged;
- Restart and reset once.