

# MAGIC BAR

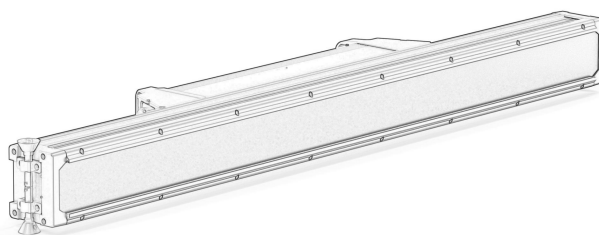

## User manual

Please read over this manual before operating the light



This product manual contains important information about the safe installation and use of the light. Please read and follow these instructions carefully and keep this manual in a safe place for future reference.

## Safety warning information

After receiving the lights, please open to check whether there is any damages caused by transportation. In case of damages caused of transportation, please don't this device and contact your dealer or manufacturer as soon as possible.

The projector is for indoor and outdoor use, IP65.

Do not install the fixtures onto inflammable surfaces directly. 

The fixture is only intended for installation, operation and maintenance by qualified personnel.

Do not project the beam onto inflammable surfaces, minimum distance is 3 meter.  3m 

Avoid direct exposure to the light from the lamp. The light is harmful to the eyes.

Do not attempt to dismantle and/or modify the projector in any way.

Electrical connection must only be carried out by qualified personnel.

Before installation, ensure that the voltage and frequency of power supply match the power requirements of the fixture.

It is essential that each projector is correctly earthed and that electrical installation conforms to all relevant standards.

Do not connect this device to any other types of dimmer apparatus.

The projector should always be installed with a secondary safety fixing. A safety cord is supplied for this; it should be attached as shown in "installing the projector" section.

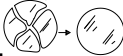
Shields and lens shall be changed if they have become visibly damaged to such an extent than their effectiveness is impaired, for example by cracks or deep scratches. 

Exterior surface temperatures of the luminaire after 5 minutes operation is 45°C, when steady state is achieved 70°C. There is no user serviceable parts inside the projector, do not open the housing and never operate the fixture with the covers removed.

There is no user serviceable parts inside this light, please check whether all covers or shells have been installed and screws have beed tightened securely. It is forbidden to use lights with covers(or shell) open.

If you have any questions, don't hesitate to consult your dealer or manufacturer.

Always disconnection from Power before the device's installation, cleaning and maintenance

# Installation

## 1. Installed on the ground

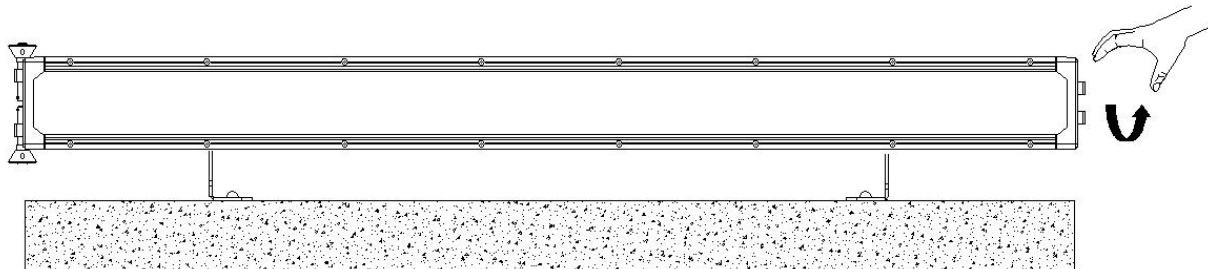

## 2. Hanging

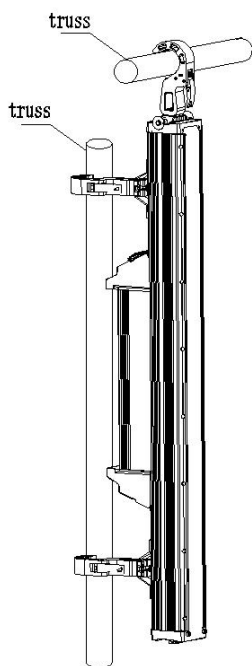

## 3. Splicing

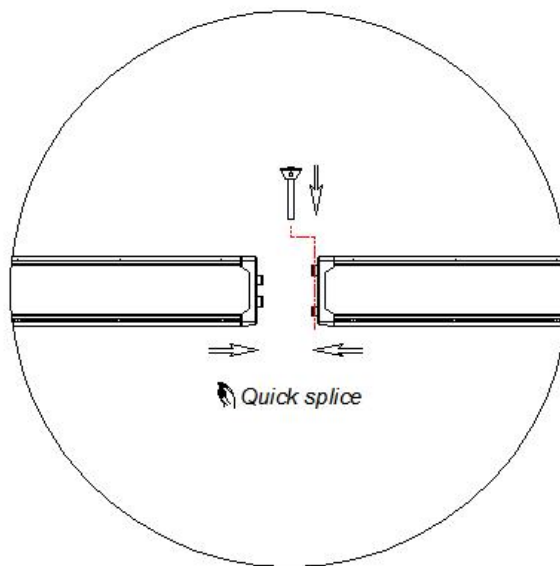

## 4. Diffuser

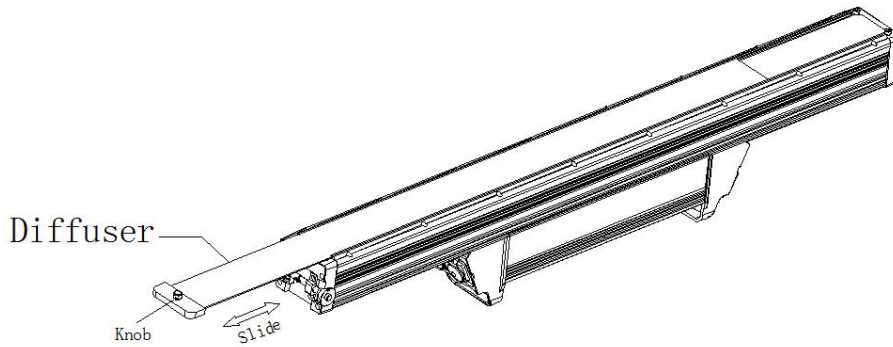

Take out 2 clamps and 1 safety rope, install the 2 clamps on the bottom of the fixture with the 4 quick knob attached to the clamps, then hang the fixture on the fixed support with the clamp, and tighten the clamp lock bolt to fix the fixture. Please confirm that the fixture installation is stable and reliable, and ensure that the hoisting position has sufficient strength to withstand the weight of the fixture. please carry the randomly equipped safety rope through the bottom of the fixture holder for auxiliary hoisting to ensure safety.

**Warn:**

- 1、 The clamps are only used when install the fixtures. It is strictly forbidden to use the clamps as a handle to carry the fixtures.
- 2、 For safety reasons, please use a safety rope that can withstand 10 times the weight of the fixture through the safety hole of the fixture body.
- 3、 Side hang the fixtures are forbidden .

## Signal and power connect

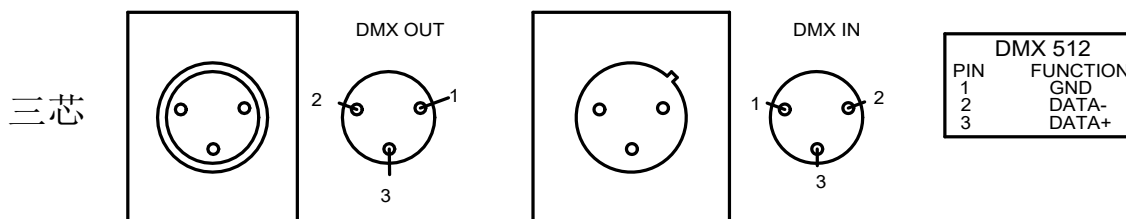

For the connection of control signals, 2-pin shielded cables with a diameter not less than 0.5 mm must be used between the fixture and the controller and between the fixtures. Please use the 3-pin signal output / incoming line of the lamp to connect. The connections between the 3-pin signal line ports are shown in the figure above. It must be noted that the 3 pin of the XLR plug / socket must not be in contact with the inner shell or between the cores when connecting. The XLR plug / socket and the XLR control cable cannot be connected in any other way than the connection shown in the figure above. This product receives the international standard DMX512 (1990) control signal.

The signal connection of multiple fixtures, the maximum number of connection is 32 fixtures, use a 3-pin signal cable from the DMX output port of the controller to the DMX input line of the 1<sup>st</sup> fixture, and connect from the DMX output line of the first fixture To the DMX input line of the second fixture, and so on, until all the fixtures are connected.

When the first fixture is not connected to the controller (the signal line connection between the other fixtures remain unchanged), it is the connection mode of master-slave synchronous control. However, to achieve

master-slave synchronization control, the first fixture should be set as the master in the menu, and the remaining fixtures should be set as slaves (the default value is slave).

When connecting the power supply, the power supply of each fixture should be connected separately. Please note that the power supply voltage and frequency must match with the power supply voltage and frequency listed in the product manual.

## Function and installation

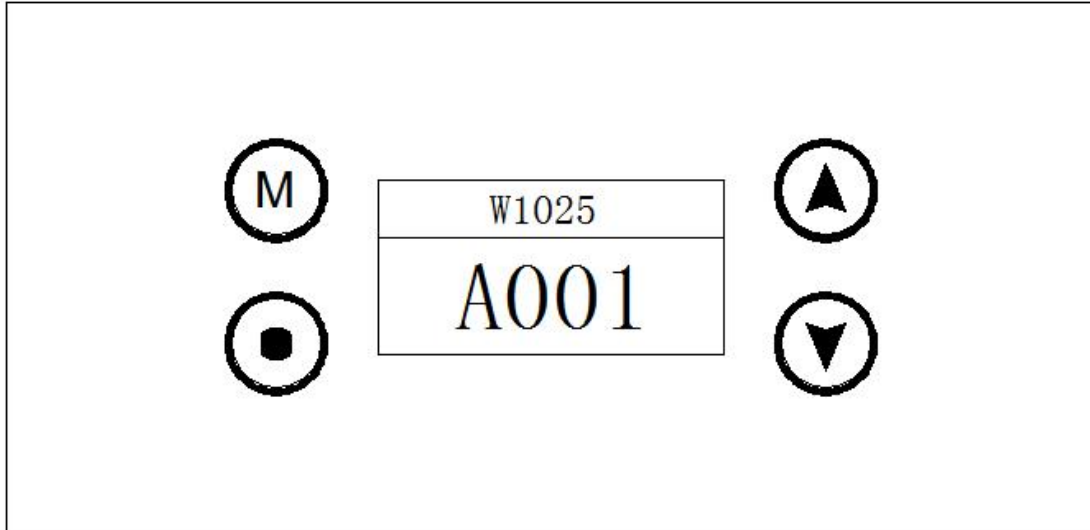

**power-on password:**  -  -  -  -

Press button  or  if you want to browse through the various Setup Options.

Press button  to save your settings or enter the next menu.

Press button  or  to shift.

Press button  will return to the upper menu one by one.

## DMX address setting

When using the controller to control multiple fixtures, each fixture shall be provided with a DMX address to receive signals from the controller and respond correctly, There are 3 control modes in this product, which are simple mode, standard mode and extent mode.

For example: The fixture has 20 channels at standard mode.

We set the 1<sup>st</sup> fixture :DMX Address 001, then the 2<sup>nd</sup> fixture DMX Address 021, the 3<sup>rd</sup> fixture DMX Address 041, the 4<sup>th</sup> fixture 61, ... ..and so on.

Turn on the fixture, If operating menu is locked, press  for 5 Sec, the fixture will be unlocked;

Then press  , or  or  to find AddR menu;

Press  , display DMX Address;

Press  /  set DMX Address value;

Press  to confirm, then the fixture automatically saved this DMX address

Press Menu will return to the upper menu

## Operation menu

power-on password: UP - DOWN - UP - DOWN - ENTER

1st LEVEL	2nd LEVEL	1rd LEVEL	1th LEVEL
DMX Address	XXX (1~499)	enter	
Net IP	IP Address	IP (0-255)	Enter
		IP (0-255)	Enter
		IP (0-255)	Enter
		IP (0-255)	Enter
	Sub tmask	255.0.0.0	Enter
		255.255.0.0	Enter
255.255.255.0		Enter	
Set Universe	Strobe Universe	0-32766	Enter
	Aura Universe	0-32766	Enter
DMX channel model	13 CH (DMX)	enter	
	64 CH (DMX)	enter	
	89CH (DMX)	enter	
	4 CH (Art-net)	enter	
	20 CH (Art-net)	enter	
OFFline statu	Hold	enter	
	Manual	enter	
	Auto	enter	
	OFF	enter	
	On	enter	
Manual Color	Dimmer	0-255	
	Strobe	0-255	
	Macro 1	0-255	
	Macro S1	0-255	

	Macro 2	0-255	
	Macro S2	0-255	
	Macro Color	0-255	
	Char1	0-255	
	Char 2	0-255	
	Char 3	0-255	
	Char 4	0-255	
	Char 5	0-255	
	Char Color	0-255	
	BackColor Red	0-255	
	BackColor Green	0-255	
	BackColor Blue	0-255	
	White 1	0-255	
	White 2	0-255	
	White 3	0-255	
	White 4	0-255	
	White 5	0-255	
	White 6	0-255	
	White 7	0-255	
	White 8	0-255	
Auto Prgram	Show RGB	0-255	
	Speed RGB	0-255	
	Show W	0-255	
	Speed W	0-255	
	Char Color	0-255	
	Char1	0-255	
	Char 2	0-255	
	Char 3	0-255	
	Char 4	0-255	
	Char 5	0-255	
Display	Ch / En	中文	
		English	
	Display Direct	Normal	

		reverse	
	Backlight	ON	
		30s	
Parameter	NO		
	yes		
Default	No		
	Yes		
Info	RDM UID		
	Channel		
	Ver		
	Time		
	Temperature		

DMX channel list



### 13 Channel

Channel	Name	DMX Value	DMX Percentage	Description
1	Dimmer	0-255	0-100%	0-100%Intensity
2	Strobe	0-255	0-100%	0-100% Strobr <b>frequency</b>
3	Macro 1	0-10	0-100%	invalid
		11-20	0-100%	Fx 1
		.....		
		245-255		Fx 25
4	Macro 1S	0-255		
5	Macro 2	0-10	0-100%	invalid
		11-20	0-100%	Fx 1
		.....		
		245-255		Fx 25
6	Macro 2S	0-255	0-100%	
7	Macro 2CF	0-255	0-100%	



8	Macro 2CB	0-255	0-100%		
9	W-S	0-255	0-100%		
10	Red-C	0-255	0-100%	0-100% red	
11	Green-C	0-255	0-100%	0-100% Green	
12	Blue-c	0-255	0-100%	0-100% Blue	
13	W-C	0-255	0-100%	0-100% White	

## 64 Channel

Channel	Name	DMX Value	DMX Percentage	Description	
1	pixel module 1 R	0-255	0-100%	0-100% red	
2	pixel module 1 G	0-255	0-100%	0-100% Green	
3	pixel module 1 B	0-255	0-100%	0-100% Blue	
3	pixel module 1 W	0-255	0-100%	0-100% W	
....	.....	0-255	0-100%	.....	
60	pixel module 16 R	0-255	0-100%	0-100% red	
62	pixel module 16 G	0-255	0-100%	0-100% Green	
63	pixel module 16 B	0-255	0-100%	0-100% Blue	
64	pixel module 16 W	0-255	0-100%	0-100% W	

## 89 Channel

Channel	Name	DMX Value	DMX Percentage	Description	
1	Dimmer-W	0-255	0-100%	0-100% Intensity	
2	Dimmer-RGBW	0-255	0-100%	0-100% Strobr <b>frequency</b>	
3	Strobe	0-255			
4	Macro 1	0-10	0-100%	invalid	
		11-20	0-100%	Fx 1	
		....			
		245-255		Fx 25	
5	Macro 1S	0-255			
6	Macro 2	0-10	0-100%	invalid	
		11-20	0-100%	Fx 1	
		....			
		245-255		Fx 25	
7	Macro 2S	0-255	0-100%		
8	Macro 2CF	0-255	0-100%		
9	Macro 2CB	0-255	0-100%	0-100% W	
10	White 1				
...	.....	0-255	0-100%		
25	White 16	0-255	0-100%	0-100% W	
26	pixel module 1 R	0-255	0-100%	0-100% red	
28	pixel module 1 G	0-255	0-100%	0-100% Green	

29	pixel module 1 B	0-255	0-100%	0-100% Blue	
30	pixel module 1 W	0-255	0-100%	0-100% W	
....	.....	0-255	0-100%	.....	
86	pixel module 16 R	0-255	0-100%	0-100% red	
87	pixel module 16 G	0-255	0-100%	0-100% Green	
88	pixel module 16 B	0-255	0-100%	0-100% Blue	
89	pixel module 16 W	0-255	0-100%	0-100% W	

#### 4 Channel(Art-net)

Channel	Name	DMX Value	DMX Percentage	Description	
1	Dimmer	0-255	0-100%	With DMX	
2	Strobe	0-255	0-100%	With DMX	
3	Macro 1	0-10	0-100%	invalid	
		11-20	0-100%	Fx 1	
		.....			
		245-255		Fx 25	
4	Macro 1S	0-255			

#### 20 Channel (Art-net)

Channel	Name	DMX Value	DMX Percentage	Description	
1	Dimmer	0-255	0-100%	With DMX	
2	Strobe	0-255	0-100%	With DMX	
3	Macro 1	0-10	0-100%	invalid	
		11-20	0-100%	Fx 1	
		.....			
		245-255		Fx 25	
4	Macro 1S	0-255	0-100%		
5	White 1	0-255	0-100%	0-100% W	
...	.....	0-255	0-100%		
20	White 16	0-255	0-100%	0-100% W	

Channel priority: dimming> built-in program call > user program call>ARGBW dimming >HSV dimming> Macro Instruction> Color Temperature

## Maintenance

To ensure the reliability of the projector it should be kept clean. It is recommended that the fans should be cleaned every 15 days. The lens and dichroic color filters should also be regularly cleaned to maintain an optimum light output. **Do NOT use any type of solvent on dichroic color filters.**

Cleaning frequency depends on the environment in which the fixture operates: damp, smoke or particularly dirty surroundings can cause greater accumulation of dirt on the unit's optics. A soft cloth and typical glass cleaning products should be used in cleaning. It is recommended to clean the external optics at least once every 20 days and clean the internal optics at least once every 30 / 60 days.

**Do not use any organic solvent, e.g. alcohol, to clean the reflector mirror, dichroic color filters or housing of the apparatus.**

## Trouble shooting

Problems	Act i on
The fixture wont switch on properly	<ul style="list-style-type: none"> <li>➤ power cord connection is not normal</li> <li>➤ the switching power supply is damaged or the connection is not normal, professional qualified technician needed to carry out maintenance and repair</li> <li>➤ control board connection is not normal , professional qualified technician needed to carry out maintenance and repair</li> </ul>
The fixture switch on , but LED not bright and not controlled	<ul style="list-style-type: none"> <li>➤ LED board connection is not normal , professional qualified technician needed to carry out maintenance and repair</li> </ul>
Switch on and light normally, but not controlled by controller	<ul style="list-style-type: none"> <li>➤ check the DMX starting address code setting is correct or not</li> <li>➤ Check the XLR signal line is damaged or not</li> </ul>
The fixture is dim and the brightness drops sharply	<ul style="list-style-type: none"> <li>➤ The fixtures temperature is too high, please take necessary ventilation and heat dissipation measures</li> </ul>

## Technical data

**Input voltage:**

AC 100V/120V/200V/220V /230V/240V 50/60Hz

**Power :**

700W@220V

**LED light source:**

Strobe Tube LEDs                      LED Type: 3535 5W 6500K LEDs  
LED Count: 144  
LED Colors: Cool-White  
LED Segments: 16

Strobe Panel LEDs                      LED Type: 5050SMD 2W RGBW 4 in1  
LED Count: 242  
LED Colors: Cool-White  
LED Segments: 32 (2x16)

Working lifetime                      50000h

**Dimmer :**

0-100% linear dimming

**Strobe :**

Electric strobe, 0.3-20pcs/sec    Max 20 Hz

**Control mode:**

International standard DMX 512signal, 3 Pin (5 Pin) DMX512 interface RDM

Wireless : 2.4 GHz W-DMX™ (optional)

Art-Net : (optional)

3 channel modes

Master-slave

Stand-alone mode

Self-test mode

**Other functions:**

Adjustable horizontal and vertical speed

Display fixture using time

Display software version number

Modular structure for easy maintenance

Speed-regulating radiator

**Connector**

Power : Seetronic Powercon Ture1

DMX: Seetronic XLR Cable Connector

Art-net : Seetronic RJ45 Connector

**Shell and protection level:**

High-strength casting aluminum alloy, IP66 black shell (white optional)

**Working temperature:**

-20°C~40°C

**Weight:**

8.9 Kg



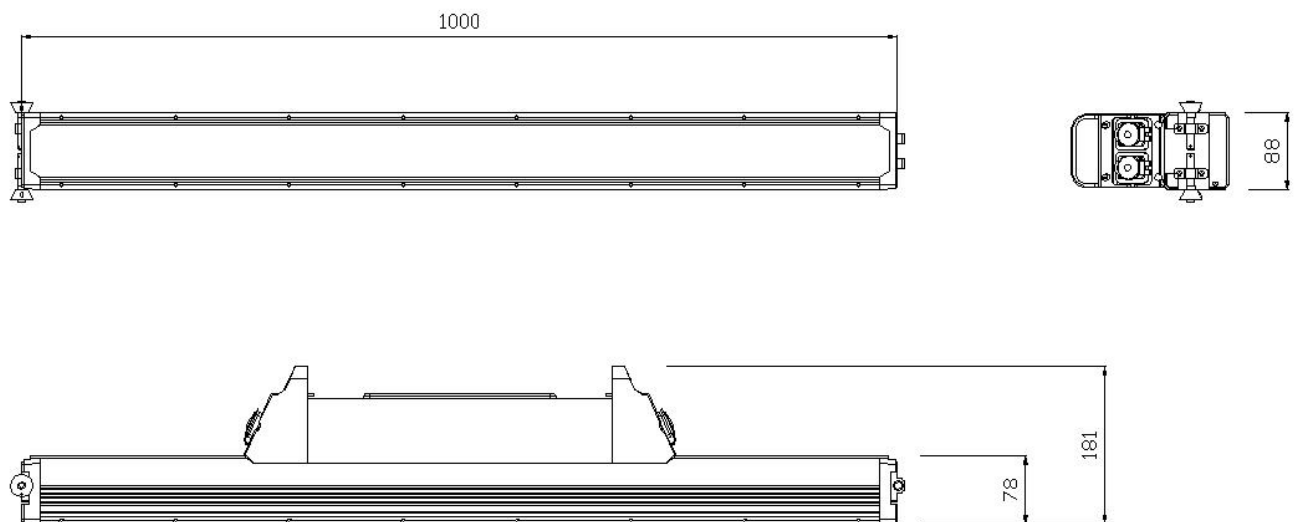

**Produce size:**

See below



**ACCESSORIES**

These items are packed together with the projector:

Name	Quantity	Unit	Remark
 <p data-bbox="264 275 389 300">This manual</p>	1	Pcs	Paper
 <p data-bbox="264 387 389 412">Power cable</p>	1	Pcs	1.5m Seetronic Powercon Ture1
 <p data-bbox="264 499 373 524">XLR cable</p>	1	Pc	1.5m
 <p data-bbox="264 611 373 636">Safety cord</p>	1	Pc	